

International Conference on Space Optics—ICSO 2020

Virtual Conference

30 March–2 April 2021

Edited by Bruno Cugny, Zoran Sodnik, and Nikos Karafolas



Final demonstration results of OPTIMA, photonic payload for telecommunication satellites



Final Demonstration Results of OPTIMA, Photonic Payload for Telecommunication Satellites

Javad Anzalchi^a, Joyce Wong^a, Valentin Polo^b, Teresa Mengual^b, Miguel A. Piqueras^{*b}, Pablo Villalba^b, Eddie Prevost^c, Karen Ravel^c, Nick Parsons^d, Michael Enrico^d, Johan Bauwelink^e, Michael Vanhoecke^e, Antonello Vannucci^f, Andrea Annoni^f

^aAirbus Defence and Space Ltd, Gunnels Wood Rd, Stevenage, Hertfordshire SG1 2AS, United Kingdom; ^bDAS Photonics SL, 8F Camino de Vera, 46022 Valencia, Spain; ^cSODERN, 20 Avenue Descartes, 94450 Limeil-Brevannes, France; ^dHuber+Suhner Polatis Ltd, 332 Cambridge Science Park, Cambridge, CB4 0WN, United Kingdom; ^eIMEC, Technologiepark, GENT 9052, Belgium;

^fCordon Srl Electronics, Via San Martino 7, Agrate Brianza, 20874, Italy

*mapiqueras@dasphotonics.com; phone +34 963 556 150; fax +34 963 562 581; <http://www.dasphotonics.com/>

ABSTRACT

One of the main challenges in space communication has always been attempting to meet the demanding requirement for greater capacity and routing complexity associated with Very High Throughput Satellite (VHTS) missions. Increased amounts of hardware associated with such high capacity mission pushes the payload towards limitation in mass, power consumption, thermal dissipation and accommodation on the spacecraft.

The objective of the OPTIMA project was to demonstrate and validate the concept of significantly improving the SWaP of VHTS payloads by defining and developing a photonic payload hardware demonstrator based on various photonic equipment building blocks and testing the demonstrator to TRL 6.

Benefits offered from the use of photonic technology in VHTS payload architectures have shown significant mass saving. This comes not only from reduced equipment unit mass but also from a lower number of units required, reduced DC power consumption and improved power dissipation.

The OPTIMA demonstrator is based on Ka-band frequency; however, a holistic approach has been taken when deriving equipment specifications by considering VHTS payload requirements as a whole to ensure the demonstrator will lead to technology developments that can easily scale up in terms of frequencies (such as Q/V band) and use in a wide range of VHTS payload architectures.

Keywords: Satellite, Optima, Photonic, payload

1. INTRODUCTION

Next generation broadband communication satellites are required to provide very high data throughput using complex multibeam architectures. These Very High Throughput Satellites (VHTS) will incorporate payloads with very large quantity of conventional RF equipment, co-axial cables, waveguides, harnesses and ancillary equipment, making the Assembly, Integration and Test (AIT) very complex. Use of 'RF over Fiber' and associated photonics equipment can make the process of AIT much simpler with the added benefit of significant reduction in number of payload equipment and inherent payload mass.

Application of multibeam concept with narrower beams and exploitation of the frequency reuse schemes have enabled a significant increase in the overall system capacity and instantaneous user data rates "as high as 100 Gbps" total capacity in the second generation of VHTS. This important technology advance has allowed satellites to be back in the course of high throughput network access solutions and have improved their suitability for the current Internet requirements. Demand for higher and higher peak data rates continues to maintain pressure on communication infrastructures since Fiber to the Home (FTTH) has replaced Asymmetric Digital Subscriber Line (ADSL) as the new reference in terms of performances.

The satellite industry is now preparing for the next evolution of the VHTS architectures through various R&D studies. Thanks to these studies it has been possible to carry out comprehensive end-to-end system assessment of such systems and propose innovative architectures capable of achieving the goal of Very High Throughput Ssatellite capacity [1], [2].

Disruptive techniques and technologies have been applied in order to define such satellite, including very large platforms, highly efficient RF power amplification, large reflectors, and usage of new frequency bands including Q/V band and optical links as well as advanced air interface techniques.

Photonics technology has already contributed to the revolution in Information Technology for terrestrial applications. However, a great deal of effort is required to bring these benefits to the world of telecommunication satellite payloads, as all of the photonics equipment used in space applications need to be adapted to endure the mechanical stress during launch and survive for 15 years in the harsh environment of a geo-stationary orbit (vacuum, thermal excursion, radiations).

This paper describes activities and the final demonstration results of the OPTIMA project. OPTIMA is funded by the EU commission under Horizon 2020, COMPET-2-2016, maturing satellite communication technologies.

The OPTIMA project aims to demonstrate and validate the photonics payload concept and its benefits and provide a strong initial impulse to the photonics payloads for telecommunication satellites by focusing the efforts of various industrial and academic actors from the photonics and space European landscape towards the concrete goal of demonstrating the validity of the photonic payload concept and associated benefits.

Since photonic technology is not yet mature for use in the space environment, the OPTIMA project aims to develop and environmentally test to TRL 6 the necessary photonic hardware payload equipment.

The project partners are: Airbus Defence and Space Ltd (UK) prime, DAS-Photonics (SP), SODERN (FR), HUBER+SUHNER Polatis Ltd (UK) and IMEC (BE), IMEC (BE) and Cordon Electronics SRL (IT).

2. DEFINITION OF PAYLOAD DEMONSTRATOR REQUIREMENTS

The payload demonstrator for the OPTIMA project focuses on the needs of high capacity multi beam system evident in VHTS missions that supports greater than 250 narrow spot beams over the coverage area with frequency reuse. Recent study and Request for Information (RFI) conducted on these VHTS missions led to the definition of the OPTIMA demonstrator requirements, and further reinforces the benefits of adopting photonic technology to enhance such system. For example, Terabit/s Satellite Study conducted by Airbus for ESA has revealed a possible saving of 25% on mass and 9% on power consumption compared to an equivalent RF payload.

Two recent RFIs, named in this paper as Mission 1 and Mission 2 were identified and their mission and payload characteristics were taken into account during the requirements definition phase alongside data from the Terabit Study. The main characteristics of the three VHTS missions studied are presented in Table 2-1.

Table 2-1 Comparison of main characteristics of VHTS missions

	Terabit Study	Mission 1	Mission 2
No. of satellites	1	1	3
No. of beams	260	359	300
Frequency bands of operation	Q/V & Ka gateways, Ka users	Q/V & Ka gateways, Ka users	Q/V & Ka gateways, Ka users
No. of gateways	33+4	18-20	16+1
DC power (kW)	~25	~22-23	~21-24 (per satellite)
Dissipation (kW)	~15	~17	~10-13 (per satellite)
Payload mass (kg)	~2580	~2290-2690	~1860-2130 (per satellite)
Total capacity (Gbps)	~1036	~442-504	~504-520 (per satellite)

The commonalities across all three missions are:

- The use of Ka-band and Q/V-band
- High number of beams, between ~260 beams to 360 beams, which translate to high mass, equipment count, power consumption and thermal dissipation.

- Frequency reuse; the available spectrum is subdivided into individual channels and translated via different LOs in order to re-assign a channel to a different beam.
- Large redundancy switch matrixes due to large equipment counts to improve reliability of the system.
- Flexibility of switching and routing of channels, sometimes involving digital processing and beam hopping.

The following considerations have been taken in determining the OPTIMA demonstrator requirements:

- To meet demanding requirements of VHTS missions using photonic hardware and to define demonstrator testing to verify that equivalent RF end-to-end payload performances can be met.
- Photonic component selections and packaging techniques to reduce mass, power consumption, footprint as well as meeting the demanding space environment reliability requirement.
- Enhance the way in which frequency reuse is supported by using photonic frequency converter capable of multiplexing channels using different conversion frequencies down a single optical path.
- Adopt optical switching to route any input to any output essential in a flexible multi beam mission.
- To Meet wideband requirement of VHTS missions; it is proposed for OPTIMA project to have RF interfaces at Ka-band only as it would be challenging to make wide band devices with acceptable performances that cover from 17.3GHz (Ka-band) to 51.4 GHz (V-band).

The transition from conventional RF payload architecture to photonic architecture is to be applied to the input section between LNAs and HPAs.

The number of LO frequencies required in a payload determines the extent of hardware savings which photonic technology can bring. Photonic frequency converter enables multiple frequency translation using one frequency mixer instead of multiple RF mixers. The output signals from different conversions are subsequently obtained using wavelength division de-multiplexing. This is in contrast to channelising the spectrum to go through separate mixers each with a different LO in a conventional RF architecture.

The feasibility of implementing photonic architecture for VHTS missions has been evaluated at payload level. A subset of paths are then selected for the demonstrator, with top level requirements flown down to equipment specification in order to align future development to real life scenarios. A simplified payload block diagram using photonic equipment is shown in Figure 2-1.

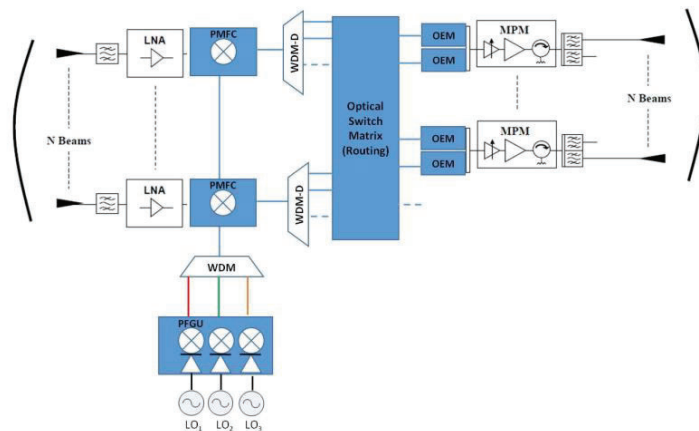

Figure 2-1 Simplified Payload Block Diagram Using Photonic Equipment

Referring to Figure 2-1, the signal from the antenna is amplified by an LNA and mixed with LOs coming from the Photonic Frequency Generation Unit (PFGU) at the Photonic Multi-Frequency Converter (PMFC). The optical signals are then routed through the Optical Switching Matrix (OSM) to the desired output beam, where it is photo-detected prior to entering the filtering and amplification RF chain before the output antenna.

3. PFGU, PMFC AND OEM MANUFACTURED MODULES

The OPTIMA photonic payload is mainly composed of four units: Photonic Multi-Frequency Converter (PMFC), Photonic Frequency Generation Unit (PFGU), Optical switching matrix (OSM) and Opto-Electronic Module (OEM). The demonstrator architecture and an overview of the manufactured system is shown in Figure 3-1.

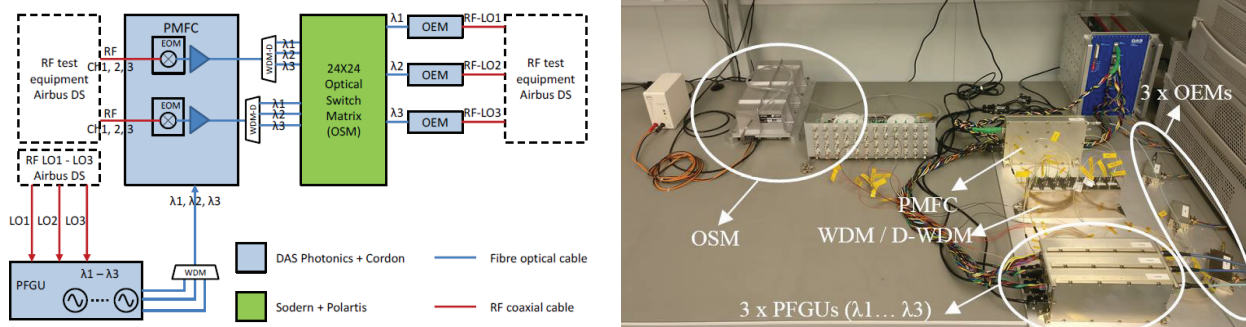

Figure 3-1 OPTIMA demonstrator architecture (left) and manufactured system (right)

Inputs to and outputs from the demonstrator are via coax cables at Ka-band frequencies, whilst all inter-equipment optical signals are connected via fibre-optic cables. The OPTIMA photonic payload incorporates wavelength multiplexers (WDM) and de-multiplexers (D-WDM) at the input and output of the PMFC (mixer) to allow LO multiplexing. DAS Photonics in cooperation with Cordon Electronics was responsible for the development of PMFC, PFGUs, OEMs and optical harness for the interconnection while SODERN in cooperation with IMEC and Polatis was responsible for raising the TRL level and ruggedizing the OSM from HUBER+SUHNER Polatis. Airbus DS was responsible for the RF input and output test equipment.

The mass and power consumption for the OPTIMA payload demonstrator (consisting of only optical equipments) with RF input and output interfaces are provided below:

- Mass: 17Kg including uncertainty
- Power consumption: 74W

3.1. Photonic frequency generator unit (PFGU)

The PFGU is an optical transmitter based on external modulation that converts an electrical LO to the optical domain, integrating also optical amplification (OA) for power conditioning, as shown in Figure 3-2 (left). The module comprises also the control and biasing electronics required to monitor and adjust parameters such as operation wavelength, temperature, output power, etc. The three manufactured modules (each one with a different wavelength to carry out the multiplexing) have been successfully tested up to 40 GHz. Figure 3-2 (right) shows one of these three modules developed during the project.

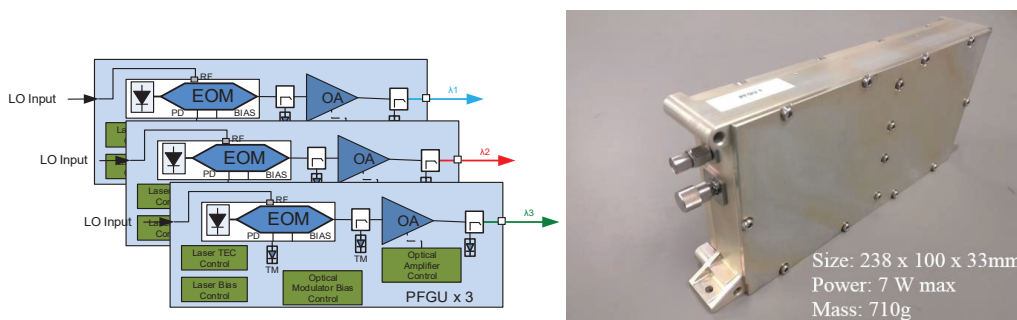

Figure 3-2 Block Diagram of Photonic Frequency Generation Unit (Left) and picture of one of the manufactured PFGU modules.

Moreover, before the module manufacturing, the photonic components integrated in each module were subjected to a test campaign focused on evaluating the impact of the radiation (Gamma and Proton), shock and temperature environmental constraints. Finally, after the modules manufacturing, each PFGU unit successfully passed vibration, shock and temperature vacuum environmental constraints to achieve TRL 6.

3.2. Photonic multi-frequency converter (PMFC)

This assembly is basically a photonic mixer that mixes the photonic LO with an RF signal to generate a set of mixing products. The mixing process is done by an optical modulator that is in charge of modulating the RF signal into the wavelengths generated by the PFGUs. This assembly integrates also optical amplification (EDFA manufactured by DAS Photonics) for power conditioning. The block diagram of the PMFC and the manufactured unit is shown in Figure 3-3 as well as the optical spectrum at the different interfaces. The optical carrier modulated by the LO signal (in red, the one corresponding to the laser at λ_1 and the two LO side-bands) is modulated by the RF signal. The LO carrier with more power (laser) generates one side-band with the information of the RF signals and at the offset from it equal to the input frequency. The secondary LO carriers generate also the same RF side-band at the same offset frequency, but the offset respect to the laser carrier is incremented by the LO frequency in one case, and decremented by this same quantity in the other case. The same process applies also for all the LO carriers generated by the PFGUs.

In the same way than for the PFGUs, the photonic components integrated in each module as well as the manufactured PFGU unit were successfully subjected to radiation (Gamma and Proton), shock and temperature (at component level) and vibration, shock and temperature vacuum (at unit level).

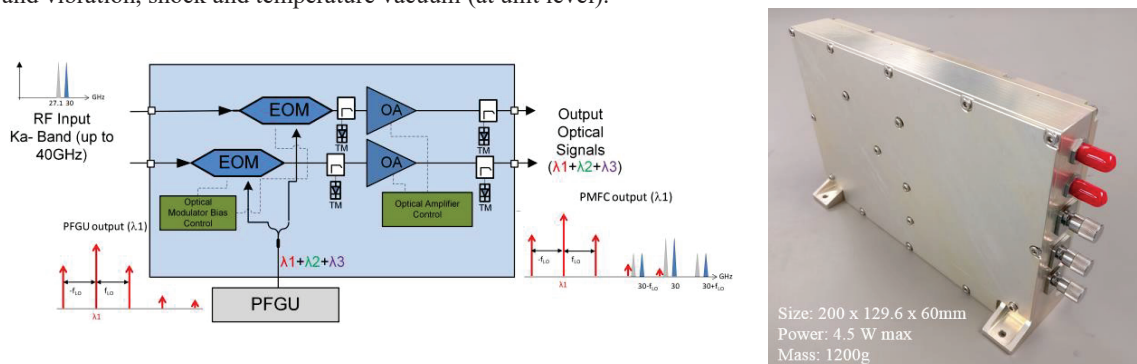

Figure 3-3 Block Diagram of Photonic Multi-frequency Converter (PMFC) and picture of one of the manufactured PMFC unit.

3.3. Optical to electrical module (OEM)

The OEM is composed by a 40 GHz Linear InGaAs PIN Photodetector and the associated circuitry. The coplanar waveguide photodiode design optimizes speed and sensitivity for the 1250 nm through 1650 nm wavelength range, and assures a 30 GHz frequency response necessary for OPTIMA specifications. As shown in Figure 3-4, the optical signal with the multiple mixing products generated in the PMFC is converted from optical to electrical in a homodyne detection process, which mathematically is described as:

$$I_{PD}[A] = R[A/W] \times |E_{OPT}|^2[W] \quad I_{PD}[A] = R[A/W] \times |E_{OPT}|^2[W] \quad (1)$$

where the I_{PD} is the photodetected current, R is the responsivity (the capacity to convert optical power in current) and E_{OPT} is the optical field arriving to the photodiode. The square of the modulus of the optical field generates mixing products of the E_{OPT} by itself, as well as other mixing product generated by the different LO carriers with the RF side bands. The IF electrical spectrum after the photodetector is shown in Figure 3-4, composed by harmonics of the f_{LO} frequency ($n \cdot f_{LO}$, $n=1,2,\dots$), replica of the input RF signal and mixing products of the input RF signal with the LO at $f = f_{RF} \pm n \cdot f_{LO}$. The desired mixing product is selected by an IF filter at the OEM output prior to be amplified and fed to the output antenna. As this filter is in the IF domain, the photonic payload can be used at any RF, LO and IF frequency.

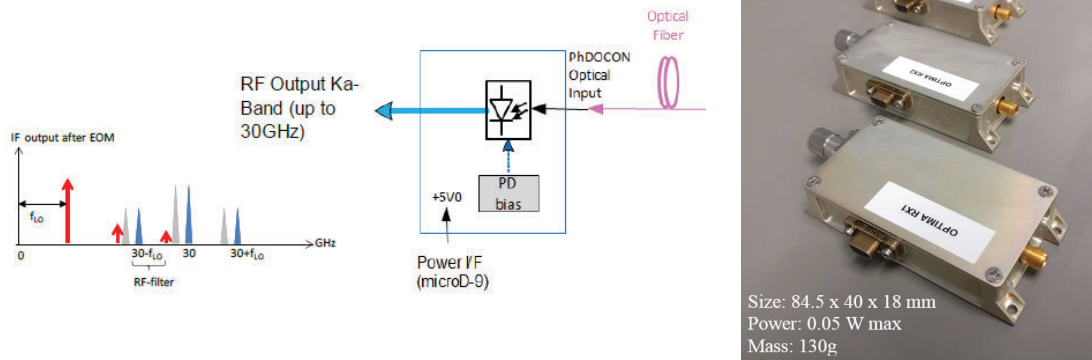

Figure 3-4. IF spectrum after OEM optoelectronic conversion (left) and picture of the three manufactured OEM modules.

In the same way than for the rest of commented modules, the photodiode integrated in each OEM module as well as each OEM module were successfully subjected to radiation (Gamma and Proton), shock and temperature (at component level) and vibration, shock and temperature vacuum (at module level).

3.4. Component and module level environmental characterization

At component level, the targeted test campaign was focused on evaluating the impact of the radiation (Gamma and proton), shock and temperature environmental constraints on the photonic components. The test conditions for the thermal, shock and radiation tests are summarized in Table 3-1.

The following test matrix was proposed taking into account the developments expected in the project, since most of the components have been already used in previous projects by DAS.

Table 3-1 Photonic component-level test conditions

Test	Test Requirement	Additional Test information
Thermal cycling	-20 to 65 °C 100 cycles (TBC), ramp at 8-9°/min, and soak for 15 min	The parts will be tested ON
Radiation (TID)	150 Krad Flux 0.36 – 15 krad/h (TBC according TID facilities and setup disposition)	The parts will be tested ON
Radiation (Proton)	Energy 60 MeV Fluency 5e10 p/cm2 Flux 1e8 p/cm2/s Circular with 5cm diameter PCB-beam output distance: 4cm	The parts will be tested ON
Mechanical Shock	According MIL-STD-883 Method 2002	The parts will be tested OFF

Figure 3-5 shows different pictures during the photonic components environmental tests.



Figure 3-5. Pictures during photonic components level characterization. Temperature cycling (left up), mechanical shock (left down), TID (right up) and Proton test (right down)

At module level, the targeted test campaign was focused on evaluating the impact of the vibration, shock and temperature vacuum environmental constraints on the different units PFGU, PMFC and OEM as summarized in Table 3-2.

Table 3-2 Module-level test conditions

Test	Test Requirement		Additional Test information	
Vibration	Frequency (Hz)	PSD		Modules will be tested OFF
		EQM / PFM 180 s / 60 s	FM 60 s	
	10	(2.10E-3 g ² /Hz)	(0.94E-3 g ² /Hz)	
	10 - 90	+9.00 dB/oct	+9.00 dB/oct	
	90 - 300	1.50 g ² /Hz	0.667 g ² /Hz	
	300 - 440	(-14.74 dB/oct)	(-14.76 dB/oct)	
	440	0.23 g ² /Hz	0.102 g ² /Hz	
	440 - 1255	(-8.04 dB/oct)	(-8.14 dB/oct)	
	1255	0.014 g ² /Hz	0.006 g ² /Hz	
	1255 - 2000	-6.00 dB/oct	-6.00 dB/oct	
2000	(5.53E-3 g ² /Hz)	(2.37E-3 g ² /Hz)		
Overall Level	(22.2 g _{RMS})	(14.8 g _{RMS})		
Shock	Frequency (Hz)		Modules will be tested OFF	
	SRS (g) all axes			
	100 Hz	20 g		
	3000 Hz	1300 g		
10000 Hz	1300 g			
TVAC	10 cycles (2 'OFF' + 8 'ON') -40 to +75 °C non operating -20 to +65 °C operating ramp at 2-3°/min pressure ≤ 10-5 mbar		Continuous monitoring of the functional parameters during the test.	

Figure 3-6 shows different pictures during the photonic components tests.

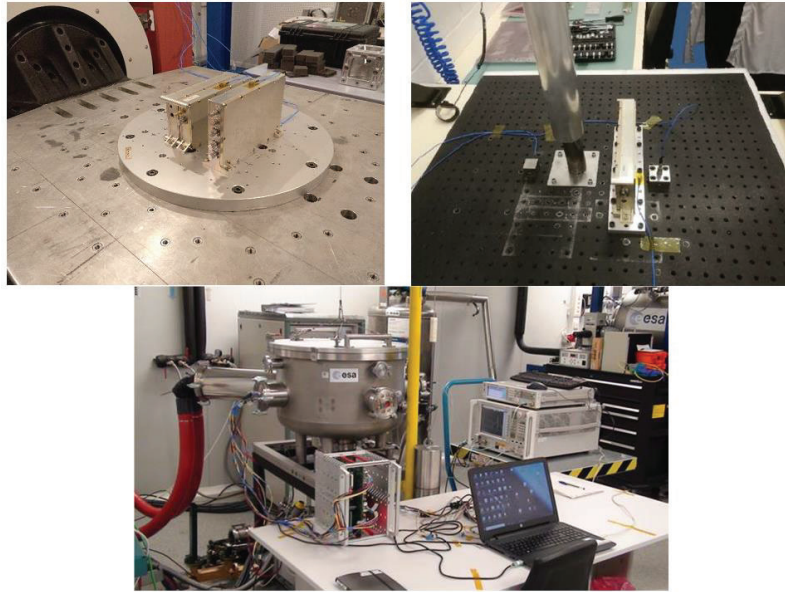

Figure 3-6. Pictures during module-level characterization. Vibration (left up), Shock (right up) and TVAC (down)

4. OPTICAL SWITCH MODULE

The optical switch is at the core of the photonic payload. It enables the routing of signals from any input port to any output port providing a high flexibility to the payload. It is fully transparent and can handle 1.55 μm signals independently of their wavelengths, intensity and modulations.

In OPTIMA project, Sodern and HUBER+SUHNER Polatis are developing a fully space qualified product by leveraging the state of the art DirectLight® terrestrial technology from Polatis.

The current Polatis optical switch matrix addresses the terrestrial telecom and datacenter markets, with a core technology currently supporting up to 384x384 ports. This is the only identified solution for addressing a large number of ports while reaching 1dB of insertion loss for space applications. The principle of the DirectLight® is shown in Figure 4-1.

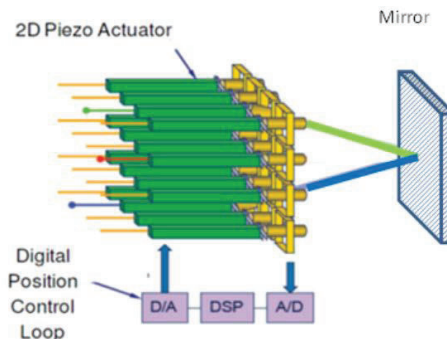

Figure 4-1 DirectLight® core technology with mirror reflection based configuration

Each input fiber is terminated by an optical collimator to generate a parallel beam. The collimator orientation is piloted by a 2D piezoelectric actuator. The position is controlled by a local closed loop using an integrated position sensor in

order to cancel piezo hysteresis, creep and drift. The collimator is then pointed to the desired output oriented collimator. The output collimator focuses the beam on the fiber end, and injects the light in the fiber. The link between two ports is established when input collimator and output collimator are aligned facing each other.

At optical switch level the main objectives in the frame of OPTIMA project were:

- To validate that the Polatis DirectLight® technology can be used for space and demonstrate overall absence of showstoppers regarding the critical space environment or processes and materials,
- To design, manufacture, test and qualify a 48-port Switch Core Unit breadboard (24 inputs - 24 outputs) with Polatis COTS EEE (Thermal Vacuum, vibrations, shocks),
- To deliver the breadboard for implementation and testing in the OPTIMA Payload Demonstrator to demonstrate steps to TRL 6.

4.1. Materials and process of DirectLight® technology

Sodern with support from Polatis has performed an in-depth analysis of DirectLight® core technology materials and processes. About 15 materials, 5 mechanical parts and 20 processes, of the manufacturing line (machines, tools, test benches, monitoring too), electronic assemblies, soldering, gluing and welding processes have been successfully reviewed to determine their compatibility with space standards.

4.2. Switch ASIC radiation evaluation

The latest, most compact, optical switch products of Polatis uses a high-voltage CMOS ASIC to drive piezo-actuators that has been specifically designed for the terrestrial communication market switch [4]. IMEC with the support of Sodern has performed first evaluation of the capacity of the ASIC to withstand radiations as shown in Figure 4-2. The aim was to evaluate the possibility to reuse this ASIC which was not specifically designed for use in space environment.

First, Total Ionizing Dose tests have been performed. There was no degradation up to 27 krad, however, a full loss of functionality has been observed at 59 krad. In depth shielding analysis has demonstrated that the use of a 3.5 mm thick packaging would be sufficient to make the ASIC compatible with the GEO environment.

Second, the sensitivity to single event effects induced by heavy ions has been tested. Failure of samples has been observed at low energy (LET of 5.7 MeV.cm²/mg) and flux (1E5 particles/cm²) at nearly the same spot despite the use of an external de-latching circuit protection. The failure mechanism has been identified as a Single Event latch-up or a Single Event Burnout. This means that the ASIC cannot be used as is in the GEO environment due to its high sensitivity to heavy ions.

In order to better understand the exact origin of the internal failure, a laser spot scanning test of the ASIC has been performed. The conclusion is that several circuits of the ASIC are sensitive to injection of charges. As a consequence a local modification of the terrestrial ASIC will not be sufficient to improve its robustness with regards to Heavy Ions.

IMEC, Polatis and Sodern are now investigating different options for the redesign of a new ASIC for use in orbit. Most issues can be addressed by well-known design and layout techniques, however, the high-voltage part makes the new design particularly challenging, possibly requiring a change in ASIC technology.

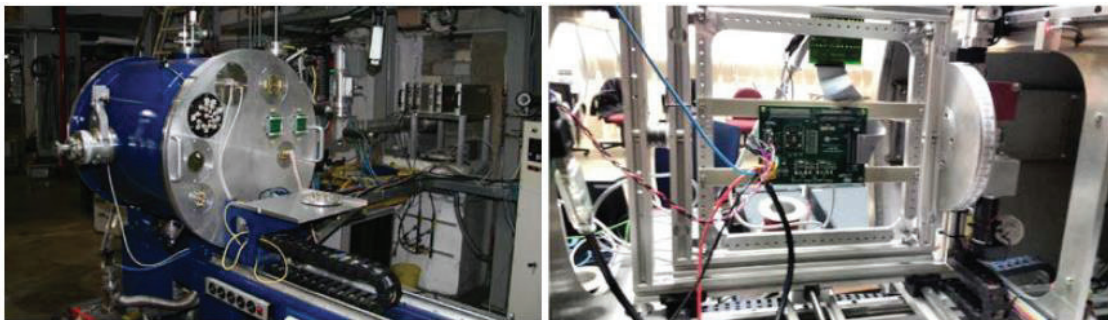

Figure 4-2 ASIC Radiation Tests

4.3. 48-port switch breadboard design

Sodern has performed an extensive vibration test campaign on Polatis switch core technology to characterize its dynamic mechanical behavior and the cause of vibration failures observed at relatively low input level compared to the vibration environment induced by rocket launch.

In parallel Finite Element Modeling Analysis has been performed to establish a correlation with experimental results and numerical test improvement solutions. Simulations have shown that several vibration modes were the reason for the failure. The local stiffening of some elements (via a change of material and design), and the use of mechanical dampers have been identified as solutions to dramatically enhance the robustness with respect to vibration and shock. Based on these results a 48-port switch breadboard was designed and manufactured jointly by Sodern and Polatis as shown in Figure 4-3.

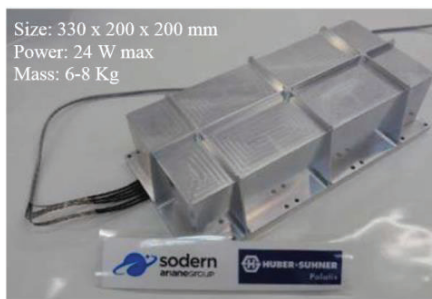

Figure 4-3 Picture of the Optima 48-port switch breadboard

Full optical switching performances of the upgraded breadboard of the optical switch matrix have been measured and are compliant with the expected results. The breadboard was then subjected to 20g sine vibrations, 16g rms random vibration, -40 to +70 °C thermal vacuum cycling and shock up to 1300g. Insertion loss measurements of the optical switch matrix have confirmed its performance integrity and stability Pre and post environmental tests mentioned above.

5. FULLY INTEGRATED PAYLOAD DEMONSTRATOR

The manufactured photonic payload system developed and tested to TRL6 in OPTIMA is shown in Figure 5-1

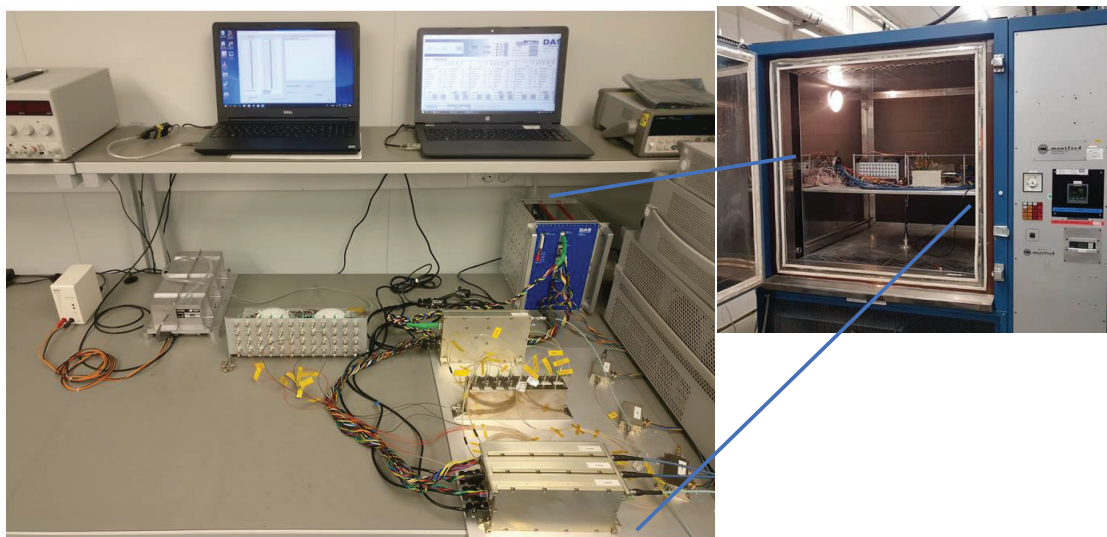

Figure 5-1. Picture of the final OPTIMA system (left) and during final measurements at Airbus temperature chamber (right)

Figure 5-2 shows the scheme of the test bench developed by Airbus that provides overall control, monitoring and DC power resources for the demonstrator units. This test bench was used to test and validate the demonstrator.

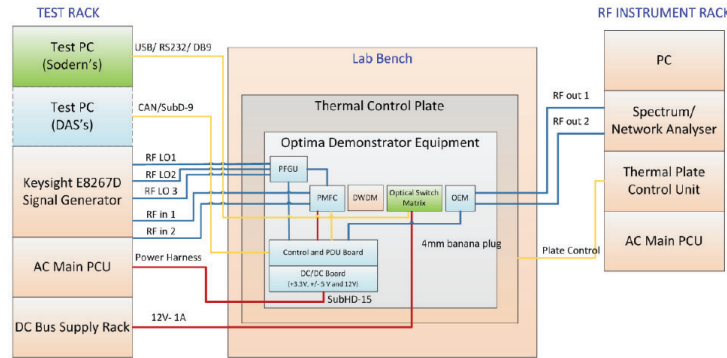

Figure 5-2. Scheme of the test bench for final RF measurements

The demonstration was comprised of three laser wavelengths set in ITU channels centered at 1558.17 nm, 1549.32 nm, and 1555.75, and the electrical LO frequencies selected for the demonstrator were 9, 10.5 and 12 GHz. A fully functional validation was carried out, measuring performance parameters such as system conversion gain, SFDR, noise figure, etc, as well as performing a fully functional dynamic validation demonstrating the flexibility of the photonic payload in terms of channel selection, routing and allocation. The TT&C system was validated as well. Figure 5-3 shows a sample of measurements carried out at different temperatures during these final tests.

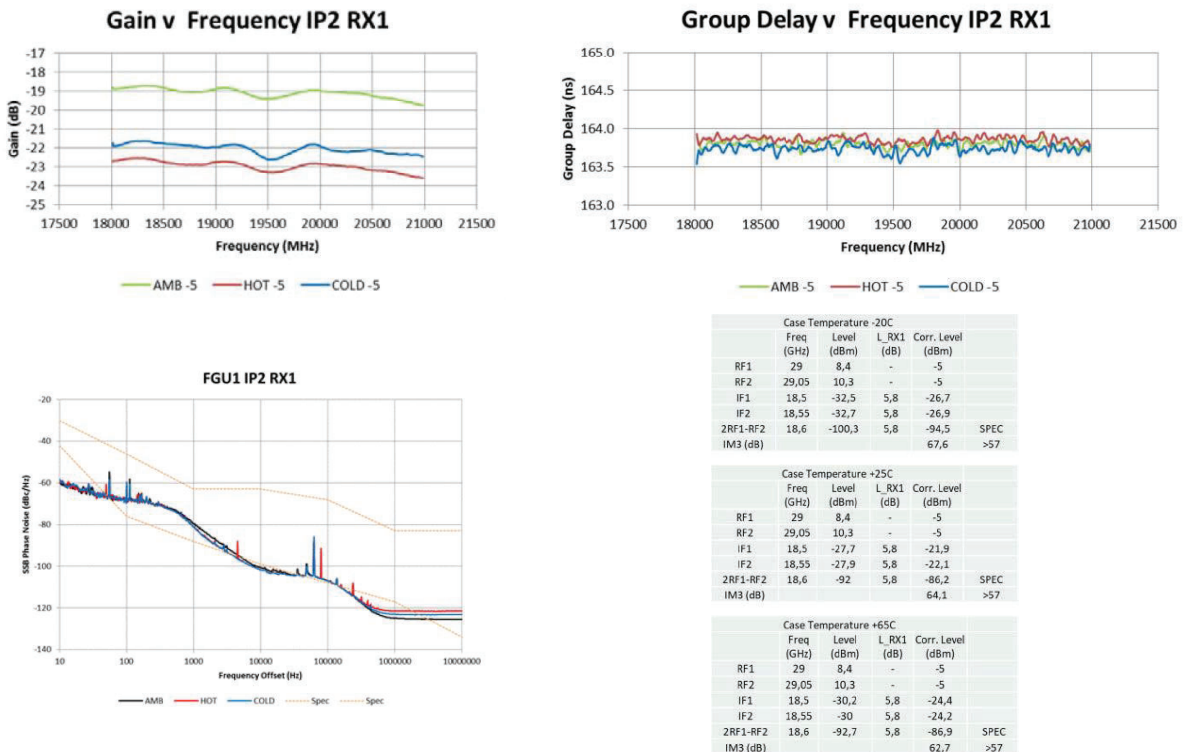

Figure 5-3. Example of final measurements in the chain PFGU1-PMFC(CH2)-OSM-RX1 at 25°C, 65°C and -20°C

The results obtained by Airbus Defence and Space in Portsmouth in the thermal chamber confirm the initial evaluation of the payload demonstrator at DAS facilities that demonstrates the feasibility and suitability of the photonic payload implementation proposed in OPTIMA for its use in next generation VHTS.

6. CONCLUSION

The present paper has outlined the final development of a photonic payload hardware demonstrator under the OPTIMA project.

To collate most up-to-date payload requirements specification for the type of high throughput broadband mission that the OPTIMA project is targeted at, recent VHTS RFIs have been included in addition to the previously terabit/s satellite study.

The optical switch matrix and the different Electro-optical and Opto-electronic modules that composes the system has passed the vibration, shock and thermal vacuum tests successfully. The successful environment testing of the OPTIMA switch breadboard paves the way to the development of a Space version of the DirectLight® switching technology in order to address the GEO communication satellite market. For the rest of the modules, similar ones have been already integrated by DAS Photonics into a commercial telecom satellites (Hispasat HIF among others) demonstrating their suitability for the new generation of GEO satellites.

An EGSE simulating the PDU and PSU and implementing the TT&C systems was development by Airbus for the final tests in order to fully validate functionality of the developed PFGU, PMFC, OSM and OEM modules. A CAN bus architecture was also designed and successfully implemented in the demonstrator. The authors would like to express their appreciation and gratitude to the European Commission and European Space agency for their continued support, funding and expert advice in the optical and photonic technology domain.

REFERENCES

- [1] G. Verelst, O. Vidal, E. Albery, D. Galinier, N. Metzger, P. Inigo, S. Stirland, G. Huggins, "Innovative System Architecture to reach the Terabit/s Satellite", 19th Ka and Broadband Communications, Navigation and Earth Observation Conference, October 2013.
- [2] P. Inigo, O. Vidal, B. Roy, E. Albery, N. Metzger, D. Galinier, J. Anzalchi, G. Huggins, S. Stirland, "Review of the Terabit/s Satellite, the Next Generation of HTS Systems", 7th Advanced Satellite Multimedia Systems Conference (ASMS) and 13th Signal Processing for Space Communications Workshop (SPSC) (ASMS/SPSC 2014), September 2014.
- [3] J. Anzalchi, P. Inigo, B. Roy, "Application of Photonics in Next Generation Telecommunication Satellites Payloads", International Conference on Space Optics, ICSO-2014, 7-10 October 2014.
- [4] N. Parsons, R. Jensen, A. Hughes, "High radix all-optical switches for software-defined datacenter networks", 42nd European Conference on Optical Communication (ECOC), Sep. 18-22, 2016, Dusseldorf, Germany, paper W.2.F.1.