

International Conference on Space Optics—ICSO 2022

Dubrovnik, Croatia

3–7 October 2022

Edited by Kyriaki Minoglou, Nikos Karafolas, and Bruno Cugny,

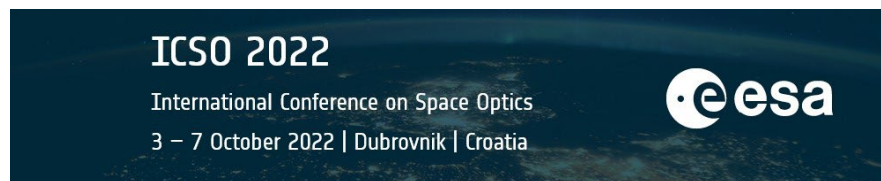

Design of the EnVisS instrument Optical Head



Design of the EnVisS instrument Optical Head

Beatrice Tofani^{a*}, Riccardo Gabrieli^a, Giuseppe Impiccichè^a, Chiara Graziosi^a, Leonardo Tommasi^a,
Demetrio Labate^a, Fabio Belli^a, Chiara Ciccirelli^a, Claudio Pernechele^b, Paola Zuppella^{c,b}, Paolo
Chioetto^{c,b,d}, Simone Nordera^{c,b}, Geraint H. Jones^{e,f}, George Brydon^{e,f}, Anamarija Stankov^g,
Vincenzo Della Corte^h, Vania Da Deppo^{c,b}

^a Leonardo Spa, Via delle Officine Galileo 1, Campi Bisenzio, Firenze, Italy;

^b INAF-Osservatorio Astronomico di Padova, Vicolo dell'Osservatorio 5, 35122 Padova, Italy;

^c CNR-Istituto di Fotonica e Nanotecnologie, Via Trasea 7, 35131 Padova, Italy;

^d CISAS G. Colombo, Università di Padova, Via Venezia 15, 35131 Padova, Italy;

^e UCL, Mullard Space Science Laboratory, Holmbury St. Mary, Dorking, Surrey RH5 6NT, UK;

^f The Centre for Planetary Sciences UCL/Birkbeck, Gower Street, London, WC1E 1BT, UK;

^g ESA/ESTEC Keplerlaan 1, 2200 AG Noordwijk, The Netherlands

^h IAPS-INAF Via del Fosso del Cavaliere 100, 00133 Roma

ABSTRACT

The EnVisS (Entire Visible Sky) instrument is one of the payloads of the European Space Agency Comet Interceptor mission. The aim of the mission is the study of a dynamically new comet, i.e. a comet that never travelled through the solar system, or an interstellar object, entering the inner solar system.

As the mission three-spacecraft system passes through the comet coma, the EnVisS instrument maps the sky, as viewed from the interior of the comet tail, providing information on the dust properties and distribution. EnVisS is mounted on a spinning spacecraft and the full sky (i.e. $360^\circ \times 180^\circ$) is entirely mapped thanks to a very wide field of view ($180^\circ \times 45^\circ$) optical design selected for the EnVisS camera.

The paper presents the design of the EnVisS optical head. A fisheye optical layout has been selected because of the required wide field of view ($180^\circ \times 45^\circ$). This kind of layout has recently found several applications in Earth remote sensing (3MI instrument on MetOp SG) and in space exploration (SMEI instrument on Coriolis, MARCI on Mars reconnaissance orbiter). The EnVisS optical head provides a high resolved image to be coupled with a COTS detector featuring $2k \times 2k$ pixels with pitch $5.5 \mu\text{m}$. Chromatic aberration is corrected in the waveband 550-800nm, while the distortion has been controlled over the whole field of view to remain below 8% with respect to an F θ mapping law. Since the camera will be switched on 24 hours before the comet closest encounter, the operative temperature will change during the approaching phase and crossing of the comet's coma.

In the paper, we discuss the solution adopted for reaching these challenging performances for a space-grade design, while at the same time respecting the demanding small allocated volume and mass for the optical and mechanical design. The view expressed herein can in no way be taken to reflect the official opinion of the European Space Agency.

Keywords: Comet interceptor, Fisheye, F θ distortion, Optical design

* corresponding author email, phone, etc (e.g. beatrice.tofani@leonardo.com; phone +39 055 8950300;)

1. INTRODUCTION

The EnVisS (Entire Visible Sky) instrument is one of the payloads of the ESA Comet Interceptor mission. Comet Interceptor is the first F-class mission of the ESA Science Program, with a target launch date by 2029, together with the ARIEL mission. The aim of the mission is the study of a dynamically new comet, i.e. a comet that never travelled through the solar system, or an interstellar object, entering the inner solar system.

The Comet Interceptor mission is composed of 3 spacecraft. One spacecraft (S/C A) will make remote and upstream in situ observations of the target from afar, to be protected from the dust environment of an active comet, and will act as the primary communications hub with Earth for all other mission elements. Two small probes (S/C B1, B2) will be deployed to venture closer to the target, carrying complementary instrument payloads, to build up a 3D picture of the comet.

The EnVisS instrument (see Figure 1-1) will be mounted on the B2 spinning probe and has been conceived to map the entire sky by using a push-frame imaging technique coupled with the rotation of the B2 probe. A very wide field of view (FOV) ($180^{\circ} \times 45^{\circ}$) optical design has been selected for the EnVisS camera to provide the entire map of the sky ($360^{\circ} \times 180^{\circ}$). As the spacecraft passes through the comet coma, the instrument will map the sky as viewed from the interior of the comet tail, providing information on the comet dust characteristics and distribution.

With the aim of reaching a technology readiness level of 6 before mission adoption, the European Space Agency has funded the study, analysis, development and testing of a breadboard of the EnVisS instrument optical head. The breadboard optical performance are optimized for ambient condition and will be verified before and after the environmental tests (vibration and thermal cycles in vacuum).

LDO is also involved in the instrument development including the definition of the system and subsystem requirements, the design of the instrument and the analysis of its performance, followed by the production and testing of the first FM model.

In this paper, the optical and mechanical design drivers and the solution adopted for the design of the EnVisS flight model will be presented; the nominal optical head optical performance will also be given.

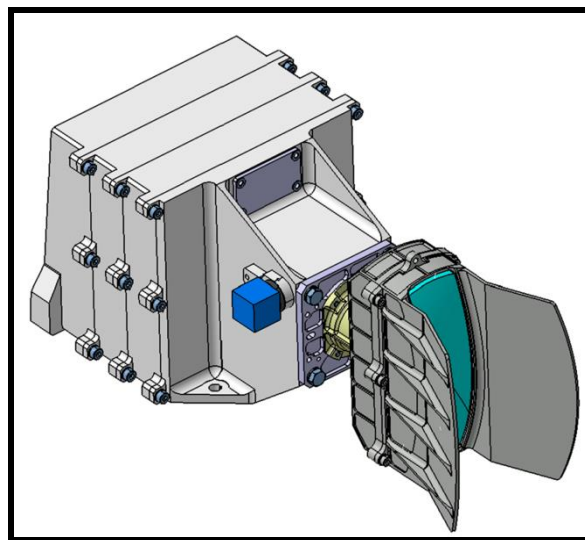

Figure 1-1: EnVisS Instrument CAD Model (Phase B1 study)

2. DRIVER REQUIREMENTS, OPTICAL DESIGN AND NOMINAL PERFORMANCE

The EnVisS optical and mechanical key requirements are listed in Table 2-1. Some of the design drivers are recognized as critical in particular: the extremely wide field of view (180°), the high control of the image distortion ($<8\%$), the optical quality (MTF) to be guaranteed for each FOV position, and the small envelope volume and low mass.

A fisheye optical layout has been selected because of the required extremely wide field of view. This kind of optical design has recently found several applications in Earth remote sensing (3MI instrument on MetOp SG) and in space exploration (SMEI^[1] instrument on Coriolis, MARCI^[2] on Mars reconnaissance orbiter). The EnVisS optical head layout, shown in Figure 2-1, is derived from the 3MI VNIR channel design^[3]. The concept is based on a reversed Galilean telescope, coupled to an imager group. The aperture stop placed between these two subsystems guarantees the system telecentricity in image space.

Table 2-1: EnVisS breadboard optical and mechanical key requirements

REQUIREMENT	VALUE
Wavelength band	550 – 800 nm
Field of view	$180 \times 45^\circ$
F-number	2.8
Focal length	3.45 ± 0.104 mm
Telecentricity	$<4^\circ$ in the whole FOV
MTF	"as-built" in flight MTF higher than 50% @ 45 lp/mm
Distortion	Distortion law f θ $<8\%$ in the nominal FoV
Mass	368g plus ~20% margin giving a total of 442.0g
Optical Head dimensions	<ul style="list-style-type: none"> - Along the optical axis (z): maximum 115mm - In the plane of the spacecraft spin axis (y): maximum 100mm - In the direction perpendicular to the optical axis and to the spin axis (x): maximum 70mm Note: for a visualization of the x, y, z reference system see Figure 2-1
Unpolarized Transparency	$> 88\%$ @ on-axis FOV, Begin Of Life (BOL)
Polarization sensitivity	$< 14\%$ in all spectral range and all FOV points
Back focal length	>8 mm
Non-operative temperature range	$-80 / +60$ °C

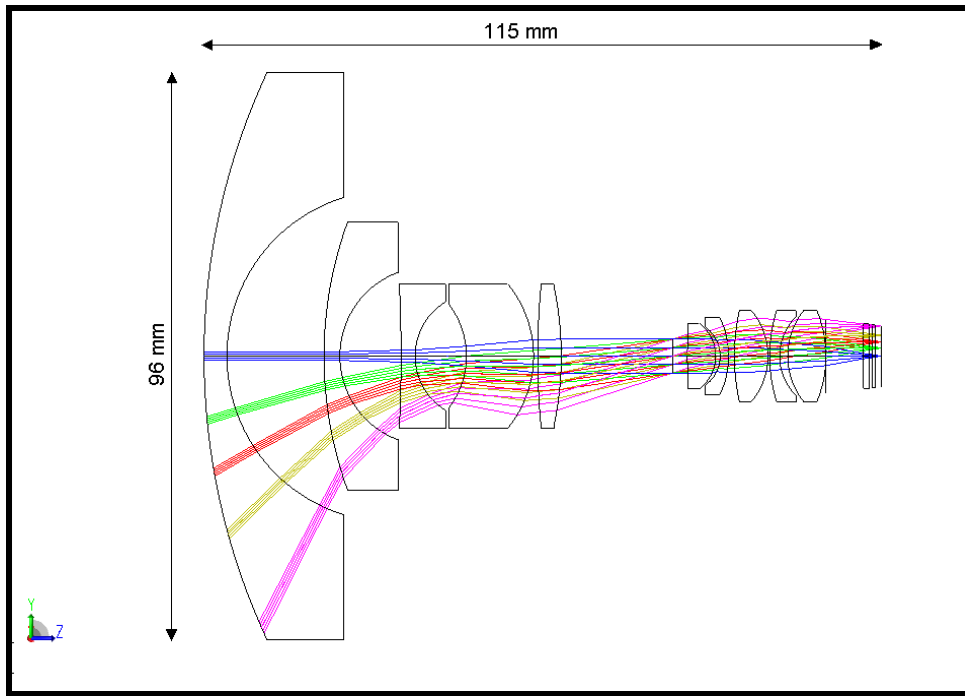

Figure 2-1: EnVisS optical head optical design

The layout is made of ten lenses without aspherical surfaces. Taking into account the space application of the optical head, the first two elements (starting on the left in Figure 2-1) are made of Fused Silica. This choice has been judged necessary to allow the optical head to withstand the radiation environment; the other internal lenses are made of Schott ordinary glasses. These are chosen to correct the chromatic aberrations in the waveband 550-800nm. In particular, because of the wide field of view, lateral color can highly affect the optical quality.

The details of the lenses materials are reported in Table 2-2.

Table 2-2: EnVisS optical head lenses materials.

LENS	MATERIAL	LENS	MATERIAL
L1	Fused Silica	L6	N-FK51A
L2	Fused Silica	L7	N-LAF34
L3	N-FK51A	L8	N-FK51A
L4	N-LAF34	L9	N-SF1
L5	N-LAF2	L10	N-FK51A

The total length of the optical system is 115 mm. The first and second lenses are rectangular and cut in the direction of 45° FOV, saving mass and volume, their dimensions in the plane perpendicular to the optical axis are 96 x 28 mm. The back focal length is 9.38 mm, necessary to enable for the assembling of the focal plane, including the Fused Silica plate simulating the detector filters and window.

The filter assembly will be made of three stripes glued on a fused silica substrate, each one covering a subpart of the FOV taking into consideration telecentricity, vignetting and footprint crosstalk. Two of them are linear polarizers with different orientation of the transmission axis, while the third one is non-polarizing. All the filter strips have a Fused Silica substrate and are coated with a bandpass filter selecting the waveband 550-800nm. The filter strip assembly is mounted on a COTS detector with format 2kx2k pixels and pitch 5.5µm.

The $f\theta$ distortion mapping law, also known as equidistance projection, has been recognized as the most suitable for the EnVisS instrument since it maintains the angular distance of different objects on the image plane^[4]. As for a typical

fish-eye design, the EnVisS distortion is mainly related to the first two lenses. In order to reduce the distortion value, the optimization of the first (L1) and second (L2) lenses had led to close to hemispheric shape for the concave surfaces, and the air gap between the two lenses had become very small. These conditions represented a possible criticality for the lenses manufacturing, anti-reflection coating uniformity and mechanical mounting design. Further optimization takes into account constraints on lens geometry and spacing to overcome these criticalities. The drawback is a reduction of the bending of the convex surfaces and a shift of the entrance pupil toward the first lens. These led to an increase in the diameter of the first and second lenses and, consequently, to an increase in mass and volume. In addition, the shift of the pupil reduces the capability to correct off-axis aberrations, in particular astigmatism, at the edge of the field of view and distortion. The final phase of the optimization was mainly driven by the balance between element feasibility, optical performances, volume and mass.

Figure 2-2 shows the nominal design polychromatic MTF (a) and spots diagram (b) for several field of view positions. The MTF is higher than 65%, allowing for margin for manufacturing, assembly and environmental performance degradation. Distortion is shown in Figure 2-3 a nominal value of about 6% is reached for each wavelength.

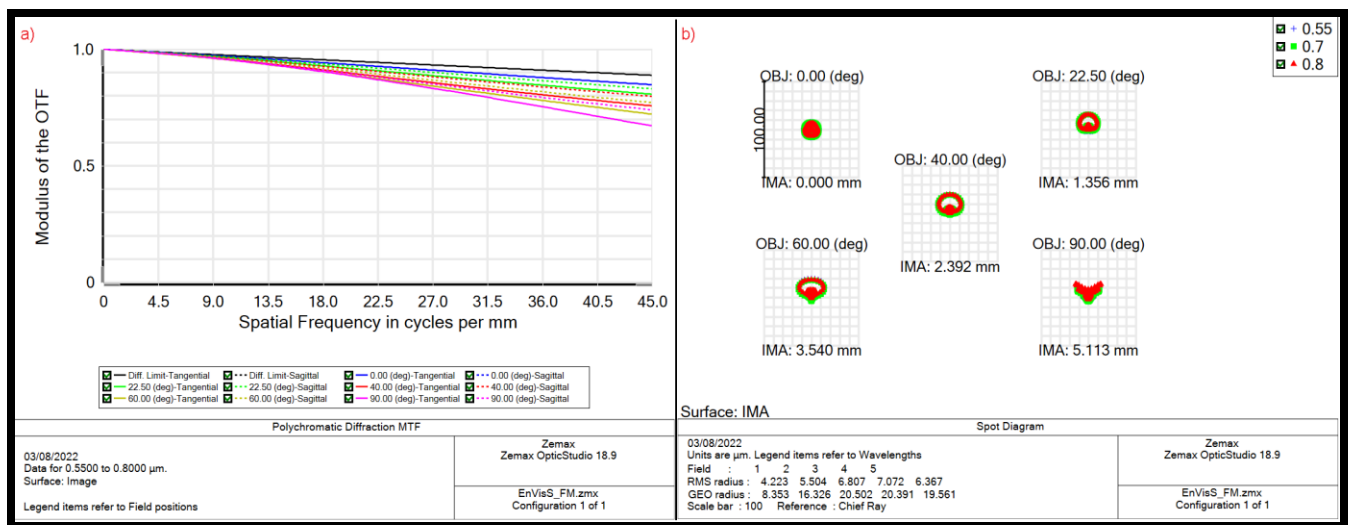

Figure 2-2: EnVisS optical head nominal design optical performance: a) polychromatic MTF up to 45lp/mm, b) spot diagram.

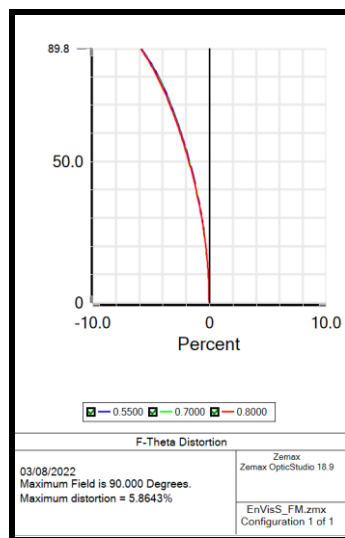

Figure 2-3: EnVisS nominal F θ distortion.

Unpolarized transmission and polarization sensitivity are derived starting from the optical head Mueller matrices assuming 100% linear polarised light. Mueller matrices are calculated over the waveband and field of view using a

Leonardo in-house code developed and successfully tested in the frame of the 3MI project^[5]. In addition, the lenses anti-reflection coatings have been selected from those designed, and space qualified, for the 3MI VNIR channel. The coating selection has been done with the aim to maximize the unpolarised transmission and minimize polarization sensitivity. Figure 2-4 shows how unpolarised transmission and polarization sensitivity vary over field of view and waveband with as-designed coatings, while Table 2-3 recaps the obtained performance.

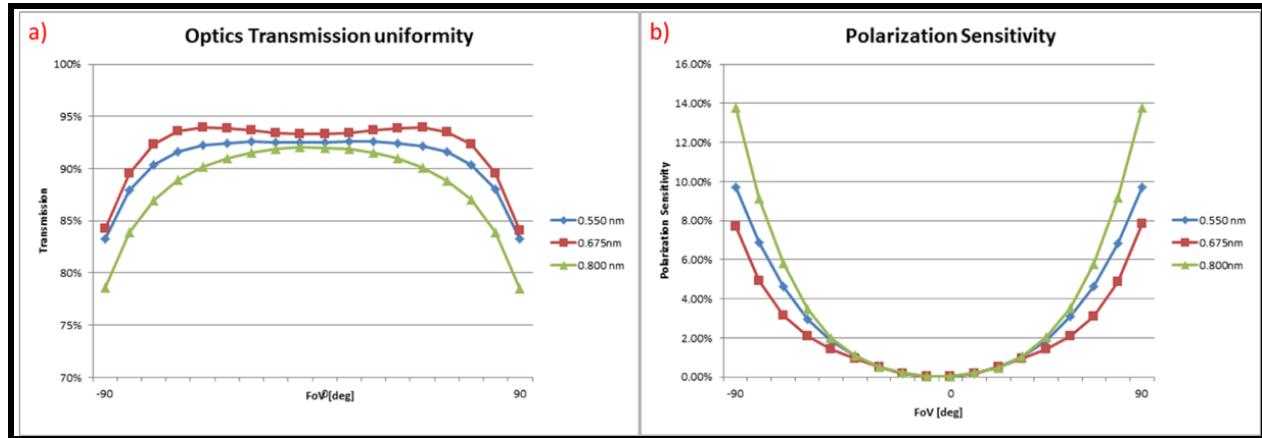

Figure 2-4: EnVisS transmission uniformity and polarization sensitivity performance. a) unpolarized transmission and b) polarization sensitivity over the waveband and field of view.

Table 2-3: EnVisS as-designed coatings unpolarised transmission and polarization sensitivity performance

PERFORMANCE	REQUIREMENTS	EnVisS performance (3MI coating)
On-axis Unpolarised Optical Transmission	> 88% BOL > 74% EOL	550nm – 92,6% 675nm – 93,3% 800nm – 92,0%
Unpolarised Optical Transmission Uniformity over FOV	NA	550nm: Axis – 92,6% ; Max FOV – 83,3% 675nm: Axis – 93,3% ; Max FOV – 84,1% 800nm: Axis – 92,0% ; Max FOV – 78,5%
Polarization sensitivity	<14%	550nm – 9,7% 675nm – 7,8% 800nm – 13,8%

3. MECHANICAL AND THERMAL DESIGN

The EnVisS optical head mechanical architecture is made of three main sub-assemblies, as in Figure 3-1:

- The front assembly is the mechanical support for both lens L1 and L2. The first two lenses being in Fused Silica are coupled with Invar36 so to minimize CTE (Coefficient of thermal expansion) mismatch of the materials. To protect the lenses these are surrounded by an aluminium shield while an extended baffle is designed for stray light control purposes and consists of one piece machined component.
- The central assembly is a titanium alloy housing that supports the lenses from 3 to 5.
- The rear assembly, made of titanium, contains the lenses from 6 to 10.

If necessary for alignment/performance purposes an optical characterisation stand-alone could be performed on the rear assembly and on the integrated assembly made of the front and central ones.

The assembly dimensions are $150 \times 100 \times 40 \text{ mm}^3$, with an estimated mass of 490 grams, including 20% margin. The structural design is preliminarily verified against 300g acceleration and a temperature excursion between -80°C and $+60^\circ\text{C}$

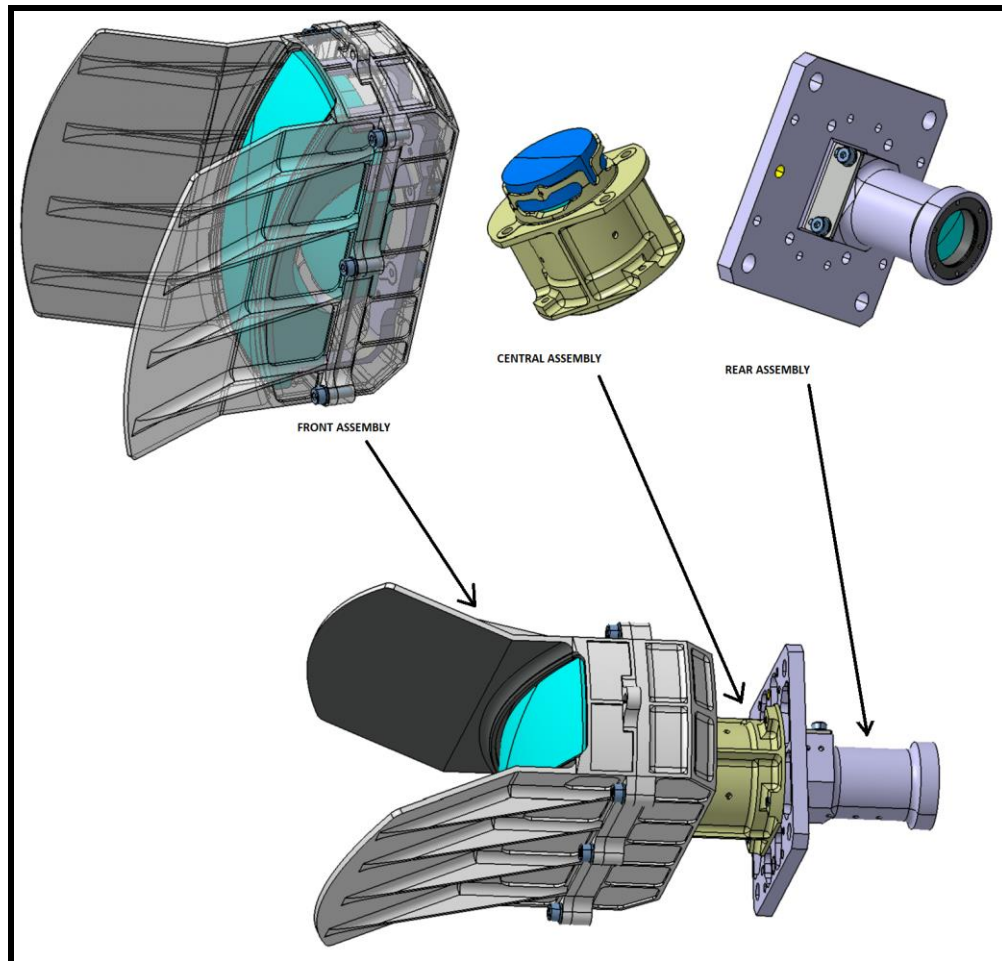

Figure 3-1: EnVisS optical head mechanical assembly

As shown in Figure 3-2, the optical head has just one mechanical fixation interface plate with 4 screws at the central assembly level. The side of the optical head in the direction of L10, i.e. the last lens towards the detector, is unconstrained.

The interface plate is also the mechanical support for the filter plate, which accommodates the filter strip assembly to be mounted in front of the detector, and the 3D+ camera itself.

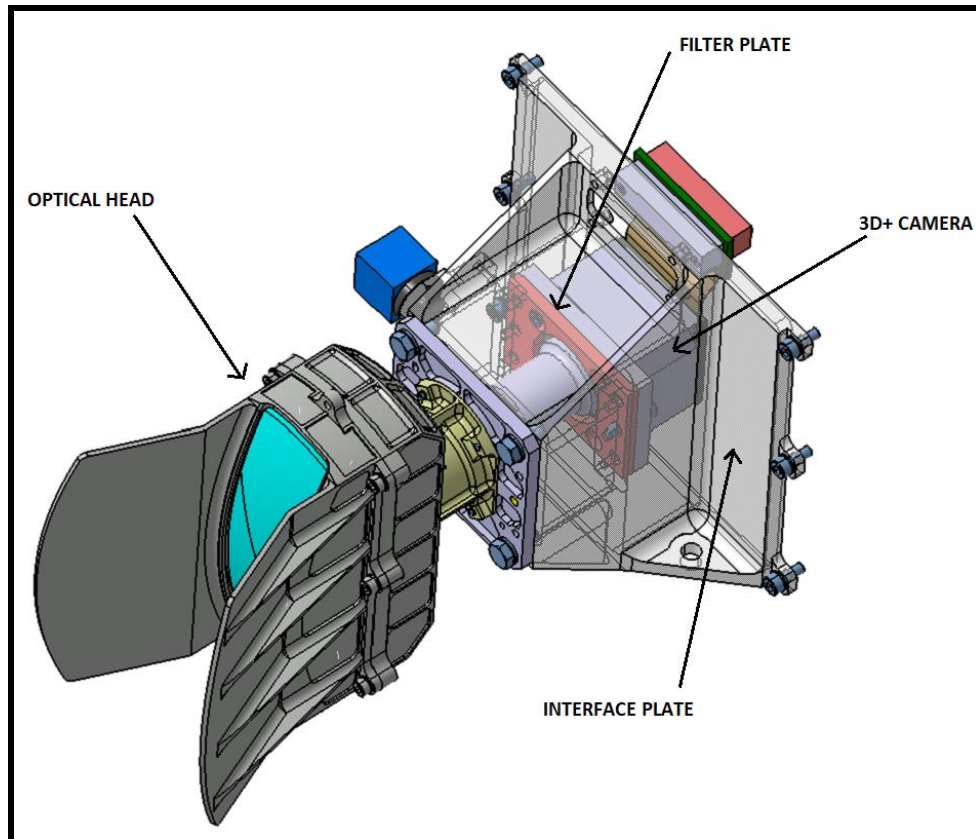

Figure 3-2: Mechanical Interface of EnVisS Optical Head

- The EnVisS optical head thermal control is based on Multi-layer insulation on the front and central assembly to shield as much as possible the optical structure from the probe surface and the external space environment on the first lens direction.
- Passive thermal control of the front baffle that is conductively insulated from the mechanical support of the front assembly.
- No power is available from the platform to be used for active thermal control (i.e. no heaters).

The optical head shall withstand the thermal excursion along the operative phases of the mission by guarantying the requested optical performances.

4. CONCLUSIONS

The overall design and nominal optical performance of the EnVis camera for the Comet Interceptor mission have been presented highlighting the requirements and challenges faced during the design process. A fisheye optical layout has been selected because of the required extremely wide field of view. The concept of the EnVisS optical head is based on a reversed Galilean telescope, coupled to an imager group with an aperture stop placed in between so to grant system telecentricity in the image space.

The layout is made of ten lenses and, taking into account the space application of the lens, the first two lenses are made of radiation tolerant glass. This paper shows the optical and mechanical design of a fisheye with an F-theta distortion lower than 6% and telecentricity less than 4°.

Disclaimer: The view expressed herein can in no way be taken to reflect the official opinion of the European Space Agency

REFERENCES

- [1] B.V. Jackson, et al., "The Solar Mass Ejection Imager (SMEI) Mission", *Solar Phys.* 225, 177–207, (2005);
- [2] Bell, J. F., III, et al., "Mars Reconnaissance Orbiter Mars Color Imager (MARCI): Instrument description, calibration and performance", *J. Geophys. Res.* 114, E08S92, (2009);
- [3] Gabrieli R., et al., "3MI OPD optical design: concept and performances", *proc. SPIE 9626, Optical Systems Design 2015: Optical Design and Engineering VI*, (23 September 2015);
- [4] Pernechele C., et al., "Comet Interceptor's EnVisS Camera Sky Mapping Function", *proc. SPIE 11203, Advances in Optical Astronomical Instrumentation 2019*, 112031M (3 January 2020);
- [5] Gabrieli R., et al., "Image irradiance distribution in the 3MI wide field of view polarimeter", *proc. SPIE 9626, Optical Systems Design 2015: Optical Design and Engineering VI*, (23 September 2015);